

#### Before assembly

- We recommend that time is taken to read the instructions before starting assembly, then follow the easy step by step guide. The instruction sheet is only a guide to the assembly. Certain items may not be shown to scale.
- Check all components prior to assembly
- This product should be assembled by no less than two people.
- Never attempt to erect the assembly in high winds.
- Drill components where indicated.



#### Recommended tools for assembly

- Cross head screw driver
- 10mm spanner
- Hammer
- Sharp knife
- Drill
- 3mm diameter drill bit
- 6mm diameter drill bit
- Spirit level
- Silicon sealant
- Step ladder

#### Dimensions

- Overall dimensions  
 H= 2320mm  
 W= 1945mm  
 D= 3050mm
- Min. recommended base size  
 W= 1820mm  
 D= 3000mm

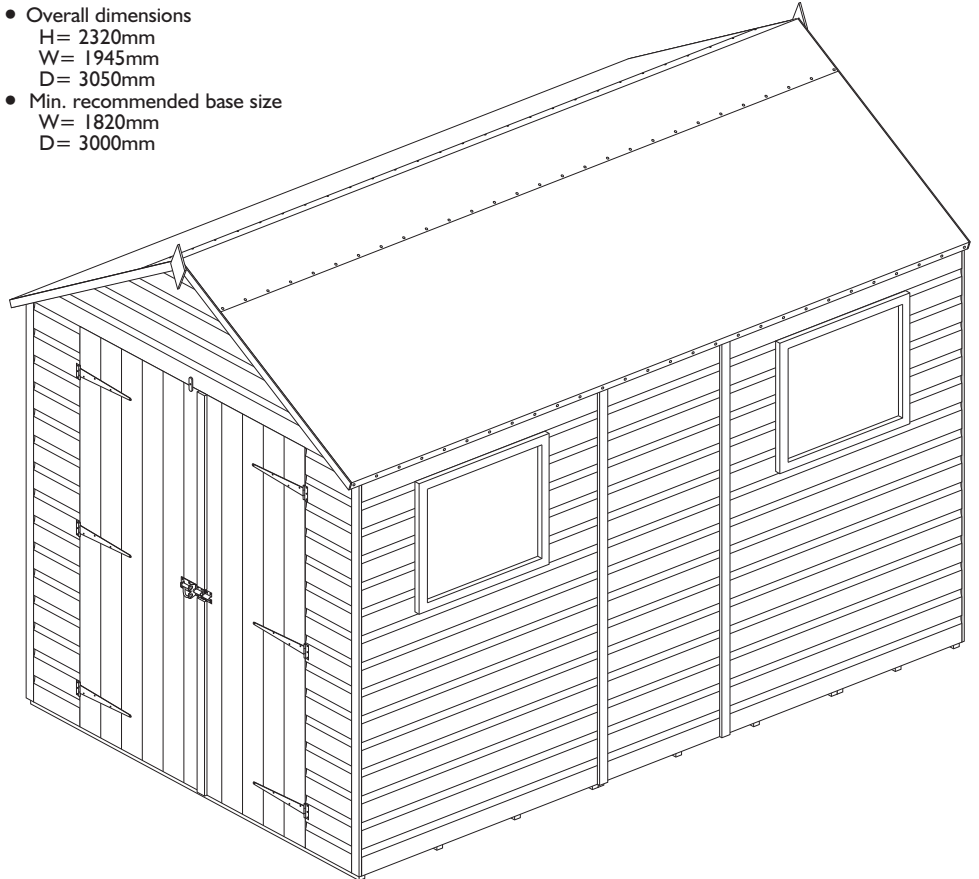

No.	Components	Qty.
1	Large floor panel	2
2	Small floor panel	1
3	Large plain panel (Width 1174mm)	2
4	Medium plain panel (Width 850mm)	2
5	Small plain panel (Width 600mm)	2
6	Window plain panel	2
7	Front panel (Width 250mm)	2
8	Apex panel	2
9	Door header rail (29 x 29 x 1200mm)	1
10	Roof rafter	12
11	Large roof panel	6
12	Small roof panel	2
13	Long felt batten (29 x 29 x 1213mm)	4
14	Short felt batten (29 x 29 x 600mm)	2
15	Felt batten block (29 x 29 x 150mm)	4
16	Left door	1
17	Right door	1
18	Door frame coverstrip (32 x 12 x 1685mm)	2
19	Roof felt (10m)	1
20	Coverstrip (12 x 47 x 1710mm)	9
21	Window frame	2
22	Window perspex (515x560mm)	2
23	Window beading (565mm)	4
24	Window beading (500mm)	4
25	Door coverstrip (12 x 40 x 830mm)	2
26	Bargeboards	4

No.	Fixing kit	Qty.
27	Roof gussets	6
28	Finial	2
29	T-hinge (254mm)	6
30	Turn button	1
31	Padbolt	1
32	Towerbolt	2
33	Storm proof hinges	2
34	Window Stay	1
35	50mm coachbolts	4
36	6mm washers	4
37	6mm nuts	4
38	63mm screws	18
39	50mm screws	51
40	38mm screws	24
41	25mm screws	60
42	22mm screws	13
43	19mm round head screws	10
44	35mm nails	145
45	20mm nails	24
46	10mm felt nails	136

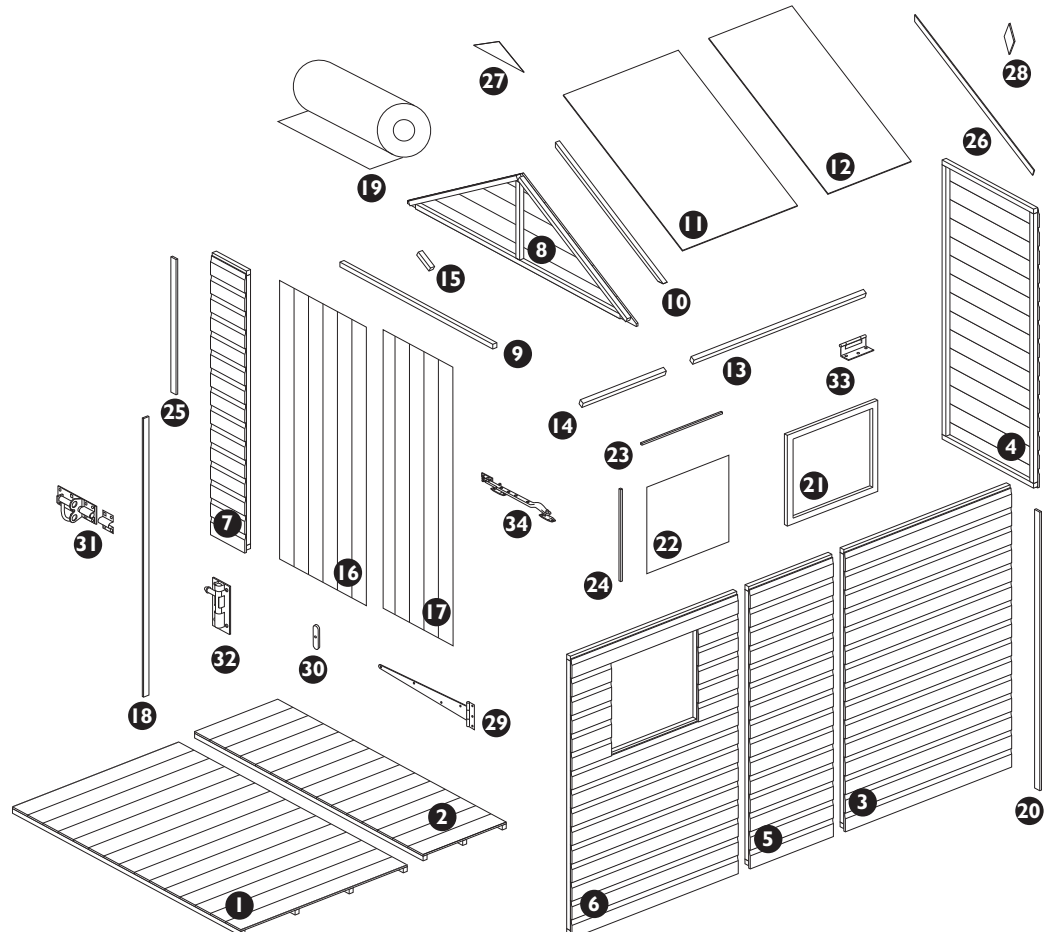

## 1. Laying the floor section

Prepare a level area for the shed to sit. With the 3 floor panels upside down, join together using 3 x 50mm screws for each join.

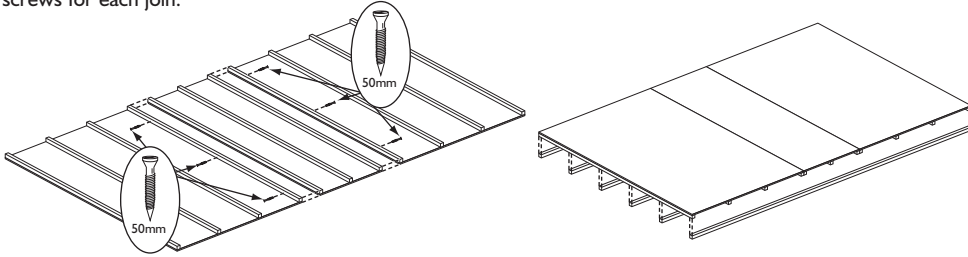

## Important note

To "VALIDATE" the guarantee, adequate provision must be made to ensure ground contact is avoided and air is able to circulate underneath the building. Placing the building on a concrete pad or slab base is acceptable provided that the building is not allowed to sit in pooled water during wet conditions. If the building is to sit on soil or grass it **MUST** be erected on pressure treated wooden 50mm x 50mm or similar bearers (**These are not supplied in the kit**). Rowlinson Garden Products recommend using pressure treated bearers with all buildings on any type of base.

## 2. Fitting the windows

For the opening window, lay a window panel on the floor. Fit two storm proof hinges in the rebates on the longer edge of the window as shown in the diagram using 3 x 25mm screws per hinge, stand the hinge end of the window on the window panel, making sure it is centred at the top of the window opening. Open the hinges and secure them to the window panel frame using 3 x 25mm screws per hinge. On the inside of the window panel fit the window stay and its two posts using 6 x 25mm screws as shown in the diagram. For the fixed window, Put the window frame into place on the other window panel, secure into place using 4 x 38mm. Screw through the side of the window frame into the framework of the window panel.

Opening window

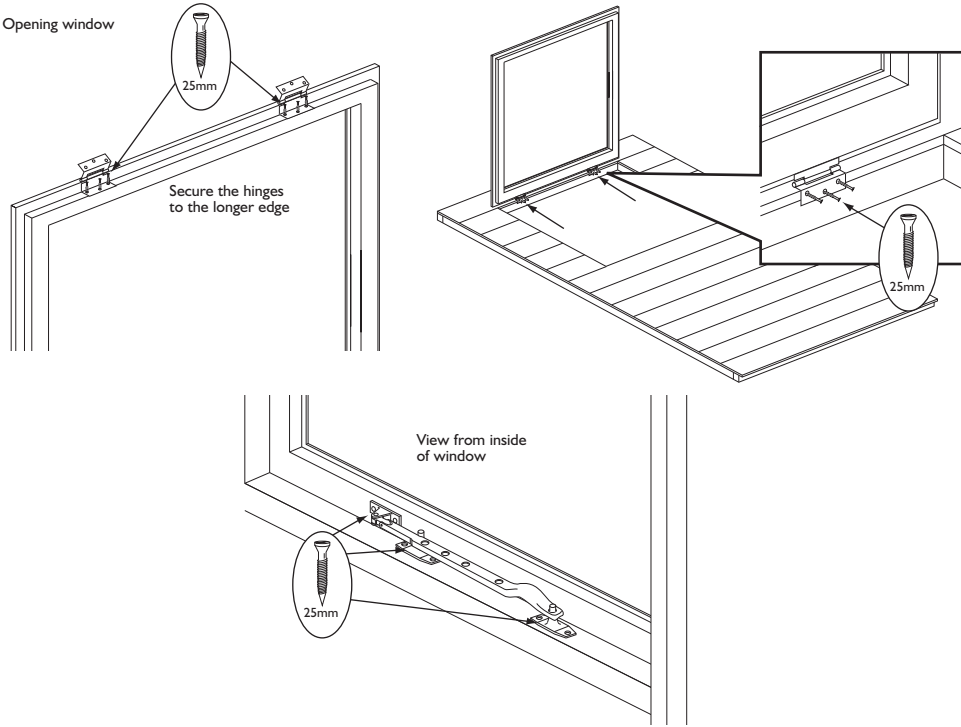

Fixed window



It is recommended to drill pilot holes with a 3mm drill for each screw.

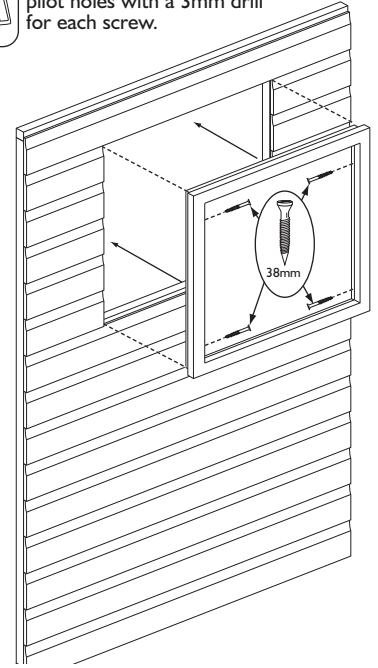

## 3. Fixing the wall panels together

Position a large panel and a medium panel as shown. Note how the panel frames sit on the floor with the panel cladding overhanging the floor edge. Ensure square and secure using 3 x 50mm screws, screw through the frame of the medium panel, into the frame of the large panel. Continue to add panels as shown below securing each one with 3 x 50mm screws.



It is recommended to drill pilot holes with a 3mm drill for each screw.

### Assembly tip.

The window panels can be interchanged with any of the large panels on the building.

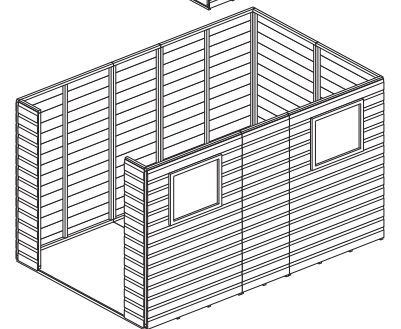
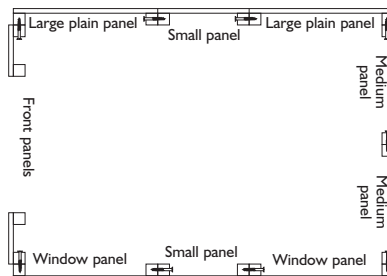
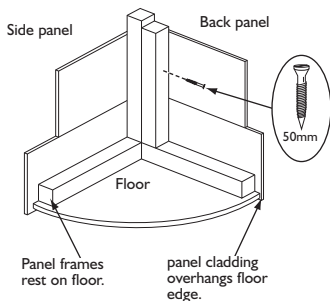
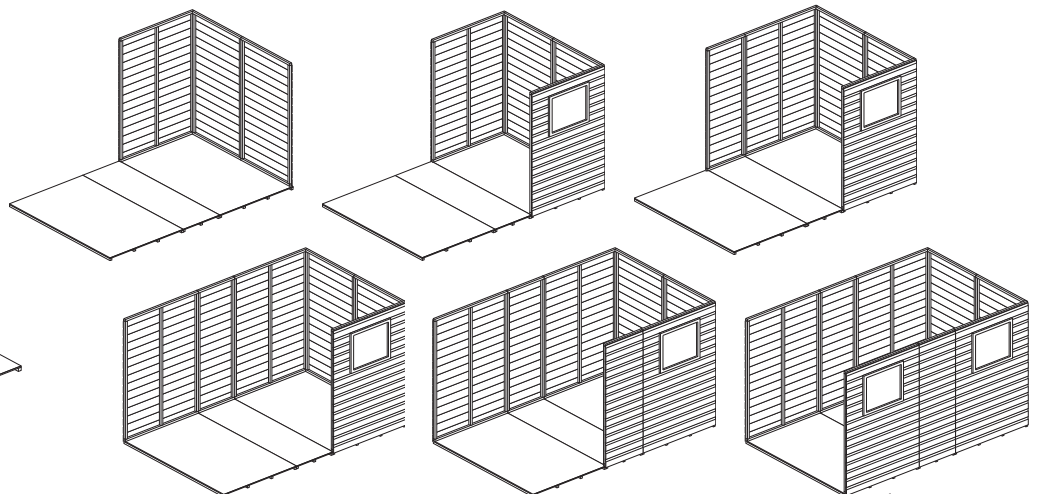
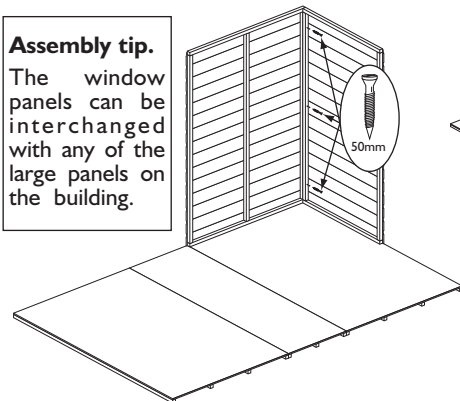

#### 4. Apex panels and door header rail and door frame coverstrips

Place an apex panel on top of the back panel, make sure the bottom shiplap board of the apex panel fits correctly into the shiplap board of the back panel. Secure by using 2 x 50mm screws, screw up through the top frame of the back panel into the bottom frame of the apex panel. Repeat for front apex. Attach to the front apex the door header rail using 2 x 50mm screws. Secure it flush to the bottom of the apex framing as shown. The door frame coverstrips are positioned between the floor and the header rail. Attach the coverstrips flush to the framing of the front panels using 4 x 35mm nails per strip.



It is recommended to drill pilot holes with a 3mm drill for each screw in this section.

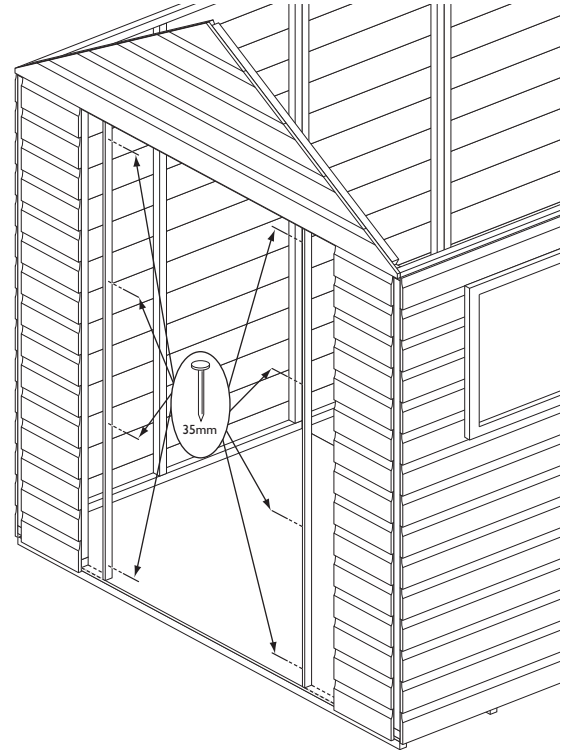
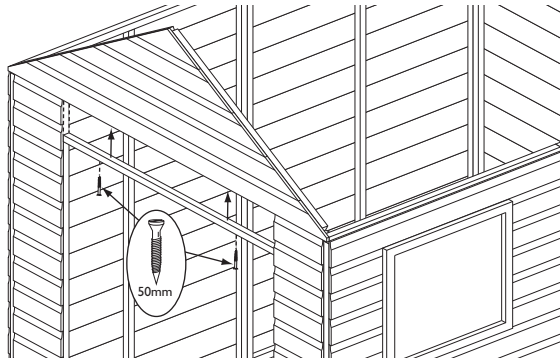
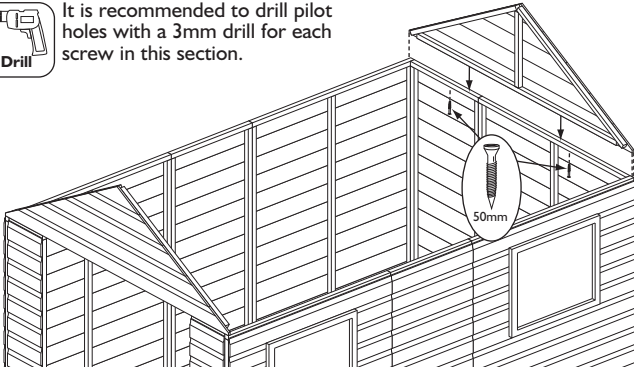

#### 5. Securing the walls to the floor

Ensure the panels are sitting square on the floor. Secure using 18 x 63mm screws, screw through the panel frames and floor into the floor joists.

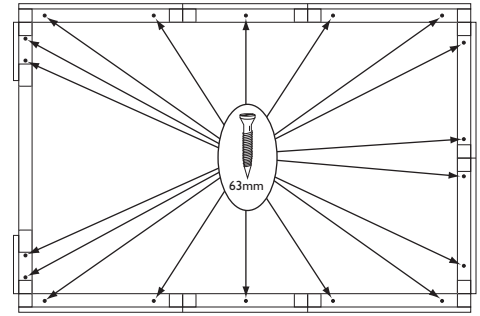
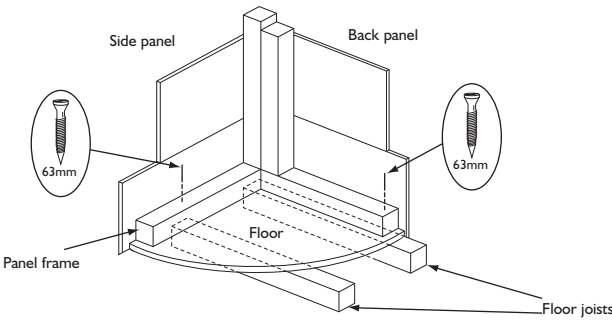

#### 6. Roof sections

To the first roof panel secure a roof rafter flush to the right-hand edge of the panel, ensure the correct angled end of the rafter is flush to the short edge of the panel as shown below. Attach using 4 x 35mm nails, nail through the panel into the rafter. To the second and third panel attach two rafters in the same way as the first with one flush down each side of the panels. To the small panel attach a rafter down the Left-hand edge. Join the four panels together using 2 x 50mm screws per joint. Screw through the the rafter of one panel into the rafter of the next as shown. Create a second roof section as a mirror image of the first as shown in the diagram noting the position of the small panel and the orientation of the rafters.

Right roof section

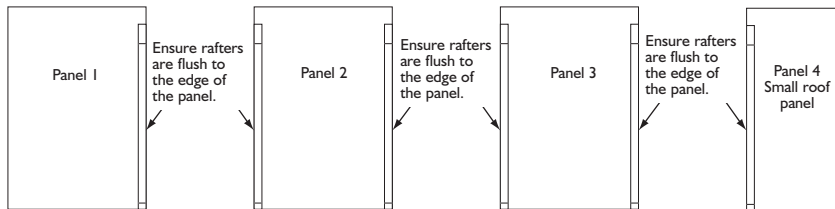

Left roof section (a mirror image off the right roof section note the orientation of the rafters).

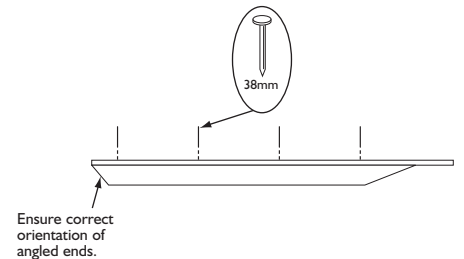
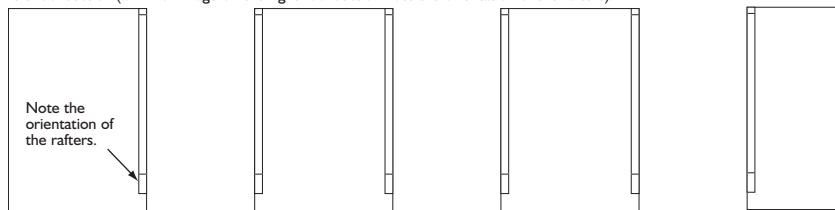

Secure panels together to create roof sections

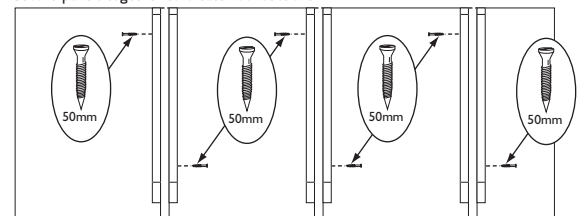

It is recommended to drill pilot holes with a 3mm drill for each screw in this section.



## 7. Fitting roof sections

Secure to the lower edge of both roof sections one short and two long felt battens using 13 x 35mm nails per section. Ensure the felt batten are flush to the edges of the panels. Flush to the front edges of each section attach the roof batten blocks evenly spaced along the edge using 2 x 35mm nails per block. Position the roof panels onto the building, make sure the top edges are located at the apex and the roof is flush with the back of the building. Secure with 10 x 38mm screws per roof section, screw through the roof and into the panel framing. From inside the building fix a gusset to both sides of the two rafters using 2 x 35mm nails per gusset.

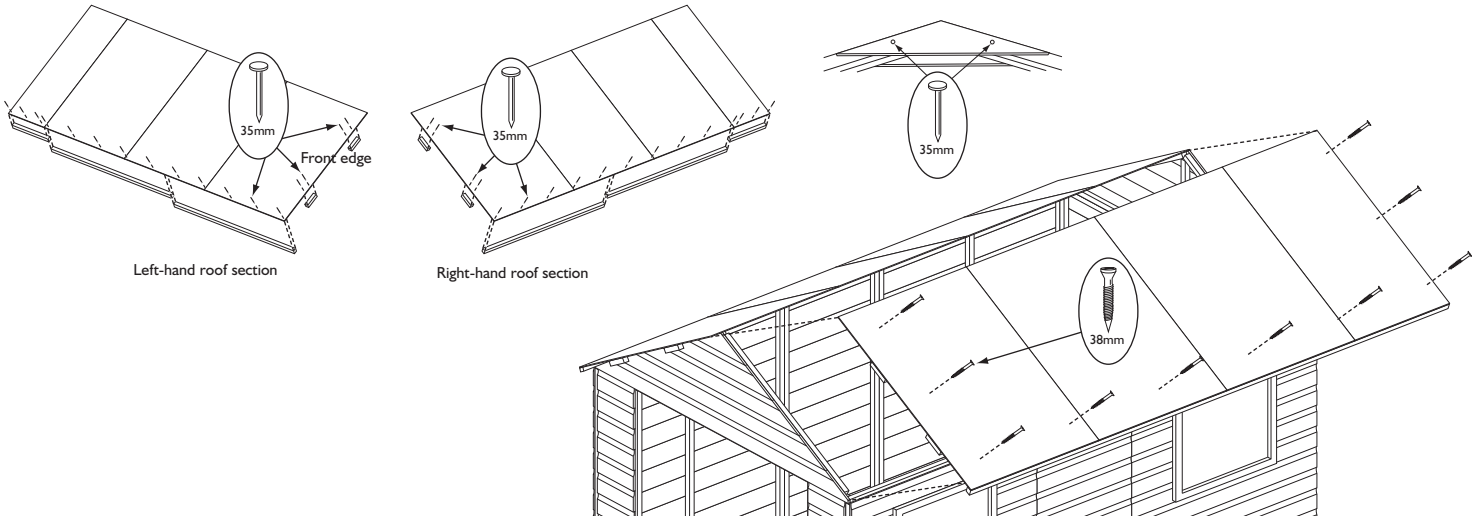

## 8. Roofing felt

Cut the roll of felt into 3 equal parts of approx. 3.3m each. Place one length over one roof section. At the front and along the lower edge of the roof leave an overhang of felt of at least 45mm. Fold down the felt along the lower edge and secure to the felt batten using 28 x 10mm felt nails evenly spaced. Tension the felt over the roof and secure along the upper edge using 6 x 10mm felt nails. Repeat this for the second piece of felt on the other side of the roof. Once the two pieces of felt are in place take the third length and place over the apex of the roof making sure it sits centrally over the roof ridge and overlaps the other two felt pieces, attach using 28 x 10mm felt nails evenly spaced, along each lower edge of the third felt. Dress down the ends of all felt pieces and attach to the batten blocks at the front with 6 x 10mm felt nails. At the back secure to the apex panel using 6 x 10mm felt nails in the same way. when all the felt is in position trim off any excess.

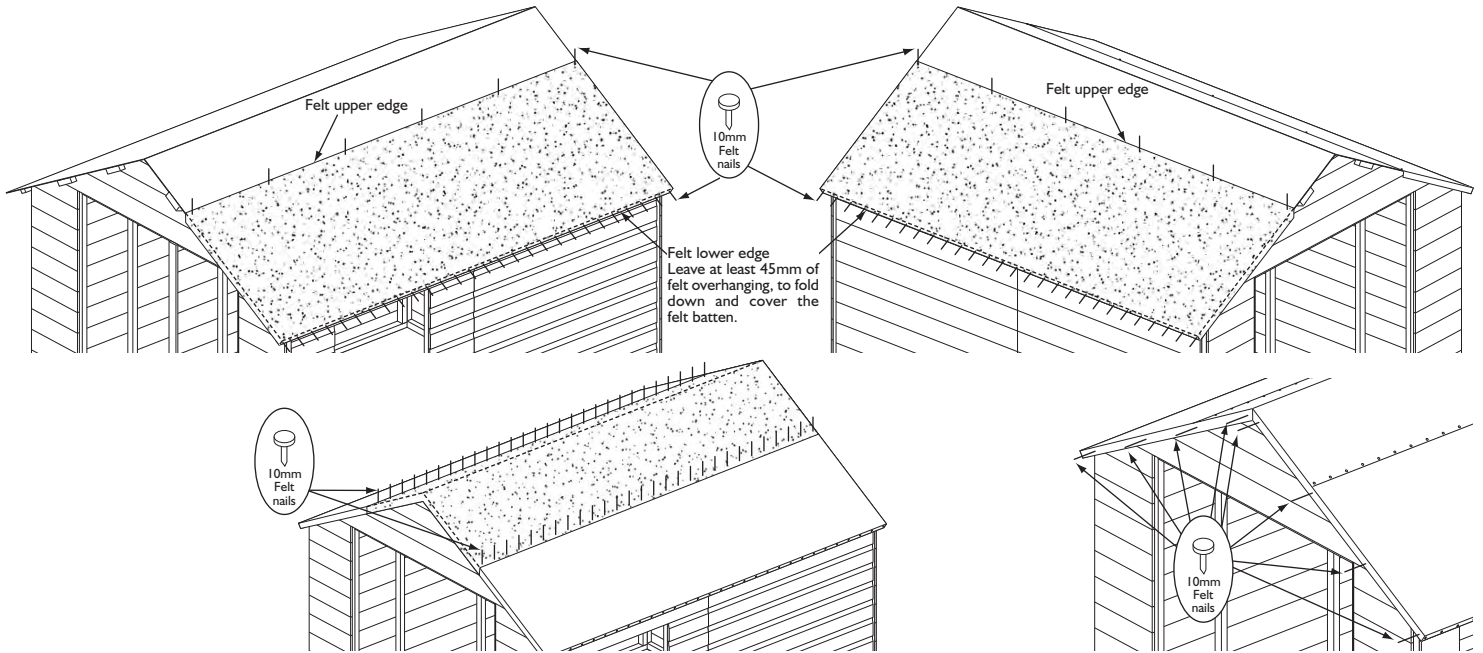

## 9. Coverstrips, bargeboards and finials

Fit a coverstrip into each corner, attach using 3 x 35mm nails per strip. The remaining five are used to cover the panel joins on each sides and back, attach using 3 x 35mm nails per strip. Attach bargeboards at the front so that the top edge is flush with the roof line and the two boards meet evenly in the middle secure using 3 x 35mm nails per board. Repeat for the bargeboards on the back. On the front attach a finial centrally over the join between the bargeboards use 2 x 35mm nails. Repeat for the finial on the back.

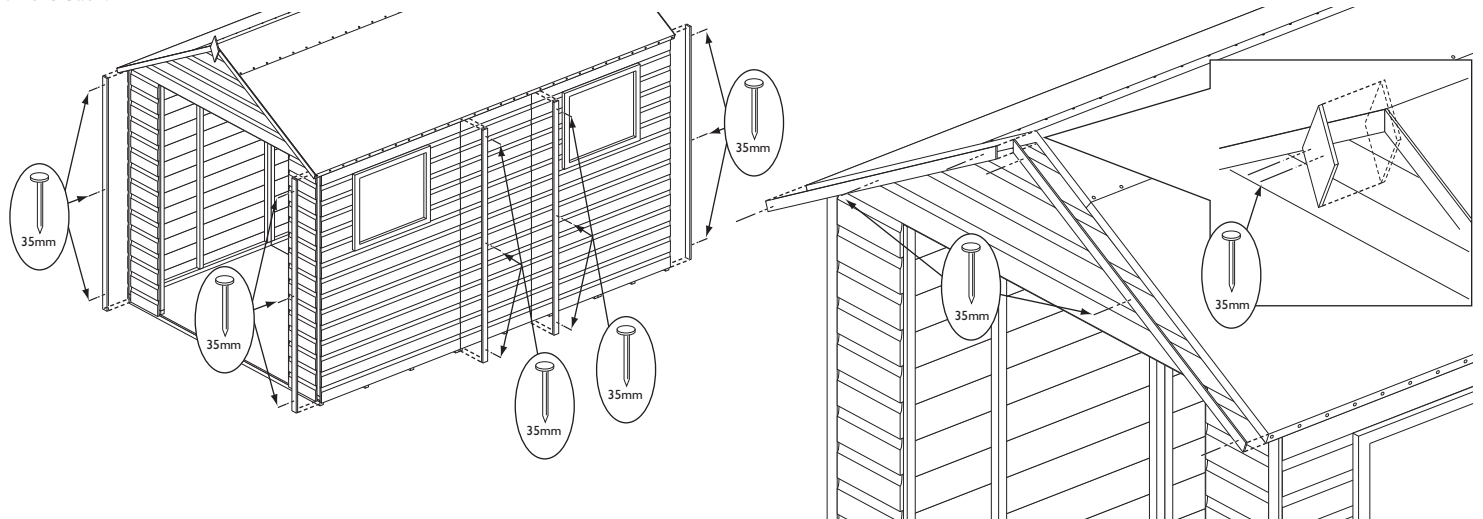

## 10. Doors

Position the doors in the opening and secure each door in place with three T-hinges and 7 x 25mm screws per hinge as shown below. On the inside of the right-hand door secure the tower bolts to the mounting blocks using 4 x 19mm round head screws per bolt. With the doors shut, position a door coverstrip so it overlaps both doors and is flush at the top of the doors, secure only to left-hand door using 3 x 22mm screws. In the same way fix the other door coverstrip flush to the bottom of the door. Fit the padbolt to the left door between the two coverstrips using 4 x 22mm screws and 2 x 50mm coach bolts, nuts and washers. It will be necessary to drill holes for the coach bolts using a 6mm diameter drill bit. Fit the catch plate to the right door using 2 x 22mm screws and 2 x 50mm coach bolts, nuts and washers, as shown below. Position the turn button just above the left-hand door secure to the apex panel using 1 x 22mm screw.

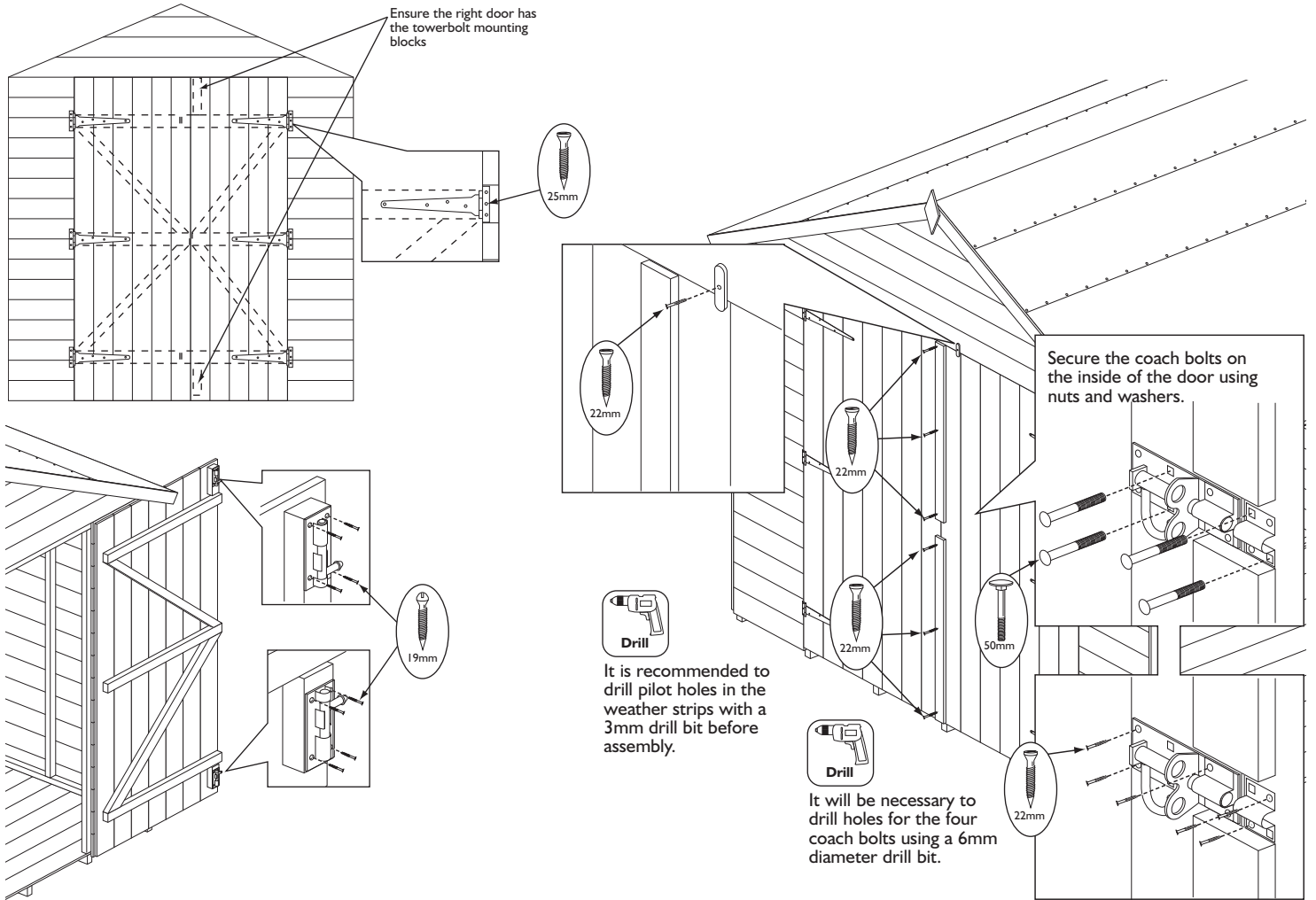

## 11. Glazing

It is recommended that a waterproof sealant is applied around the edge of the glazing before fitting. Place window pane on the inside of the window frame, nail the beading into position using 3 x 20mm nails per strip. Repeat for second window.

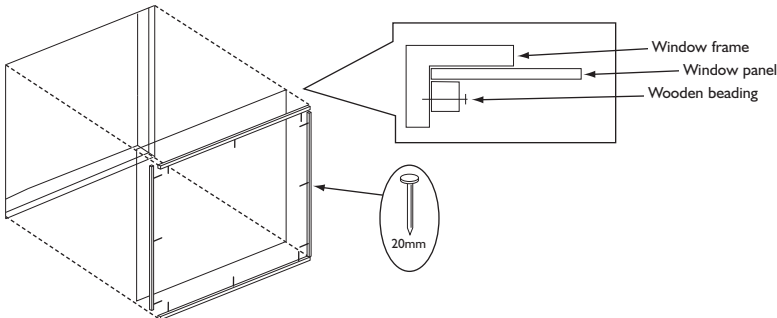

### Important information - retain for future reference

Shiplap buildings come ready stained but this is only a preparatory treatment. To **VALIDATE** the guarantee, the building must be properly treated with a recognised external wood preserver **WITHIN 3 MONTHS** of assembly and **RE-TREATED ANNUALLY** thereafter. Adequate provision must be made to ensure ground contact is avoided and air is able to circulate underneath the building.

Placing the building on a concrete pad or slab base is acceptable provided that the building is not allowed to sit in pooled water during wet conditions.

If the building is to sit on soil or grass it **MUST** be erected on pressure treated wooden 50mm x 50mm or similar bearers (**These are not supplied in the kit**).

Rowlinson Garden Products recommend using pressure treated bearers with all buildings on any type of base.

### Timber Information.

As timber is a natural material, there are certain weather conditions that may affect the materials properties. In times of excessive dry spells the material may lose some of its internal moisture causing a certain degree of shrinkage on a panel and in periods of excessive rain there will be a certain amount of swelling throughout the wooden panels. This process can not be avoided. If you have problems with certain boards shrinking in dry spells try to decrease the amount of direct sunlight on the building or the amount of air passing over the building. During hot spells spray water directly onto the panels a garden hose.

If in doubt of any aspect regarding the assembly, use or safety of your building please contact us:

**Help Line (Normal Office Hours) 01829 261121**

ROWLINSON GARDEN PRODUCTS LIMITED  
Green Lane  
Wardle Nr.Nantwich  
Cheshire  
CW5 6BN

We constantly improve the quality of our products, occasionally the components may differ from the components shown and are only correct at time of printing. We reserve the right to change the specification of our products without prior notice.

2008 © Rowlinson Garden Products Ltd